



### SEP-IT | SEPARATES CONTINUOUSLY

SEP-IT is the new generation of separation tanks from Rectus. It simply separates up to 250 liters of water per hour! One separation tank could cover the demand for separation system up to 5 units to a cost less than 40% of the costs for alternative systems for only one unit.

The SEP-IT separation tanks are made of strong materials, which are resistant to the types of chemicals used in suction cleaning remedies.

SEP-IT is made of chemical resistant polymere, stainless steel and other robust components. The smooth surface makes it easy to clean the tank.

The functional principle:

The separation tank consists of 2 chambers.

In the upper chamber, water, secretion and particles are separated from the air stream and runs into the lower chamber.

When the lower chamber is filled up, a valve closes between the lower and upper chamber. Now the water can run out of the lower chamber.

A timer reactivates the valve between the upper and lower chamber.

The water collected in the upper chamber runs into the lower chamber.

The cycle will start again.

### SEP-IT | FEATURES

Features of the Sep-it separation tank include:

- ✓ Continuous separation
- ✓ High water flow
- ✓ Strong materials
- ✓ Economic solution



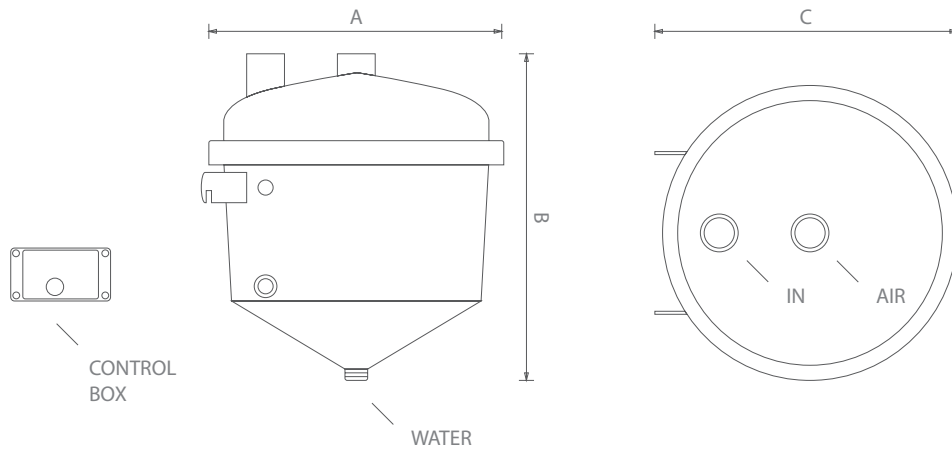

## DIMENSIONS

PRODUCT	ITEM NO.	WIDTH (A)	HEIGHT (B)	DEPTH (C)	INLET	OUTLET	OUTLET 2	WEIGHT
25L Sep-it	256001	390 mm	430 mm	400 mm	Ø 50 mm	Ø 50 mm	Ø 25 mm	9,5 kg

## ACCESSORIES

PRODUCT	ITEM NO.	WIDTH	HEIGHT	DIAMETER	WEIGHT
Suction hose	175028	-	-	Ø 25 mm	-
Suction hose	172531	-	-	Ø 50 mm	-
Amalgam filter	151191	300 mm	170 mm	-	2,2 kg

## RELATED PRODUCTS



PRODUCT	PAGE NO.
R5 Suction motor	SM 01



PRODUCT	PAGE NO.
Amalgam filter	FL 01



PRODUCT	PAGE NO.
Suction hoses	MS 01



PRODUCT	PAGE NO.
Separation tanks	ST 01